

Hydron MODULE[®] BY ENERTECH



Residential Product Catalog



Enertech Headquarters,
Greenville, IL



Enertech Manufacturing Facility
Mitchell, SD



What We Offer You

Enertech Global was founded in 1996 as a family-owned and operated geothermal heat pump distributor. Since then, we've evolved to a manufacturer, delivering award-winning innovation and the highest quality products, from design to build. When you install an Enertech-built heat pump properly, you can be confident it will perform as it should.

Building the Best

Every Hydron Module geothermal heat pump is handcrafted with pride by our dedicated employees in Mitchell, South Dakota.



Our Philosophy

We've outgrown our family-owned status, but Enertech is still and always will be family-operated, with each employee and customer a valued member of our family. When you're part of the Enertech family, you experience:

Partnership: Our relationship is based on mutual respect and success. For us to thrive, we must help you thrive. This may mean going on-site with you for a job you're trying to secure or offering training to your employees, to help them become the best they can be.

Passion: Our employees are our best asset. We work with heart from product development to taking orders, selecting appropriate accessories, and building Enertech heat pumps. Come take a tour of our factory in Mitchell, SD, and you'll see firsthand why our products are second to none: it's the passion our team has while assembling each and every product that makes you less likely to experience issues in the field.

Loyalty: We believe in earning the trust and allegiance of those who sell our products. We believe that they deserve our best quality and service,

which puts us in a distinctive position to enhance the profitability of our customers' businesses.

Customer Driven: We listen. We act. Our decisions are always guided by our customers. You can experience this by being a part of our Dealer and Distributor Councils, which meet throughout a new product design and build to ensure we're including features and benefits that enhance your business and your customer's experience.

Solution-Oriented: We're problem-solvers, acting in the customer's best interest. When something is out of our power, we work closest toward an agreeable resolution. This may mean stepping outside our processes, which certainly have their value, in order to get you what you need, when you need it.

Quality: Our team is committed to manufacturing and providing the highest quality products. Quality starts with our customers. They tell us what they need, we listen, and act on that feedback. Each unit coming off the assembly line is tested thoroughly. In fact, Hydron Module equipment

testing is the most robust in the industry with a computerized run test station, featuring helium leak detection and waterside decay testing. In the run test, each unit is tested in all heating and cooling modes, because we want every unit that leaves our factory to live up to the high standards we're known for.

To further demonstrate our commitment to customers, Enertech has been certified to ISO 9001, ISO 14001, and ISO 45001 quality and environmental management standards.

Forward Thinking: It's not just about the latest technology. With a culture of care and enduring optimism, we believe we're responsible for contributing to the well-being of the communities, cities, and countries where we do business. We're here to improve the global atmosphere and environment, so you can take peace of mind in knowing that you're working with a company that isn't just after the almighty dollar.

Experience the Enertech difference today.



"We arguably make the best product. I think I would win that argument on any given day. What's not arguable, or a question, is that we have the very best employees. This team truly sets us apart."

— Steve Smith, Enertech President & CEO



Enertech is proud to be a part of NIBE Industrier AB, an 8,000 employee strong European company and the largest geothermal heat pump manufacturer in the world.



Why You Should Go All-In on Geothermal

HOMEOWNERS NEED IT

Heating, cooling, and hot water dominate a home's energy use, accounting for approximately 65 percent of energy used. As a renewable technology that is up to 500 percent efficient and saves 30 to 70 percent on heating, cooling, and hot water costs, geothermal is the solution to meet the needs of today's homeowners.

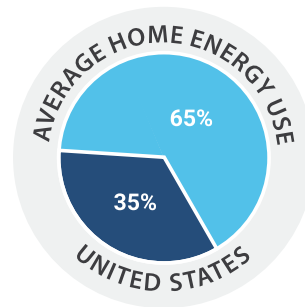

- Air conditioning, space heating, water heating
- Appliance, electronics, lighting

HOMEOWNERS CAN AFFORD IT



There's a 30% federal tax credit for residential geothermal systems, and many local municipalities, state entities, and utilities offer further rebates and incentives. Visit dsire.use.org or we'll help you contact your local utility or electric cooperative to find out more about programs in your area – or we can work to create one.

Some Canadian provinces offer incentives for geothermal. Since these offerings vary by Province, check rebates/incentives at ncran.gc.ca for more information.

We've partnered with a lending institution, Clean Energy Credit Union, that specializes in energy-efficient home improvements

to offer flexible financing. Homeowners can install a geothermal system for zero money down. Benefits include:

- The loan is secured by the installed equipment, as opposed to the home equity.
- Homeowners are eligible for loan amounts from \$1,000 to \$70,000 per loan. If loans for multiple improvements are combined, they can borrow up to \$150,000 collectively.
- Access to "competitively low fixed interest rates."
- No prepayment fees with electronic, automatic payment options.
- Access to short-term (12 or 18 months), long term (15 or 20 years), or combination loan options. The combination loan option is perfect when utilizing the federal tax credit.

We have a complete financing guide available with more details. Visit enertechusa.com/financing for more information.

Hydron Module Product Matrix

PRODUCT FEATURES	GYT Models	GVS/VT Models	GXT Models	GZS/ZT Models	GCT Models	GBS/BT Models	GRT Models	GWV Models	GWT Models	GWS Models	GHP Models
Function	Forced Air	Forced Air	Forced Air	Forced Air	Combo Forced Air/ Hydronic	Split System	Split System	Hydronic	Hydronic	Hydronic	Hydronic/ Domestic (Heating Only)
Cabinet Configuration	Multi-Positional Vertical	Compact Vertical	Multi-Positional Vertical	Compact Horizontal	Multi-Positional Vertical	Indoor Split	Outdoor Split	Water-to-Water	Water-to-Water	Water-to-Water	Water-to-Water
Compressor Stages	Two	VS: Single VT: Two	Two	ZS: Single ZT: Two	Two	BS: Single BT: Two	Two	Variable	Two	Single	Single
Sizes	2 - 6 Tons	1/2 - 6 Tons	2 - 6 Tons	1/2 - 6 Tons	3 - 6 Tons	1 1/2 - 6 Tons	2 - 5 Tons	5 Ton	3 - 5 Tons	3 - 7 Tons	2 Ton
Refrigerant	R-410A	R-410A	R-410A	R-410A	R-410A	R-410A	R-410A	R-410A	R-410A	R-410A	R-410A
Heating Efficiency (COP)* GLHP Part Load, Two-Stage Unit GLHP Full Load, Single-Stage Units	up to 5.1	up to 4.3	up to 4.8	up to 4.4	up to 4.6	up to 4.5	up to 4.6	up to 3.9	up to 3.2	up to 3.2	up to 3.2
Cooling Efficiency (EER)* GLHP Part Load, Two-Stage Units GLHP Full Load, Single-Stage Units	up to 31.3	up to 27.2	up to 29.1	up to 29.8	up to 26.8	up to 28.9	up to 27.2	up to 25.4	up to 20.2	up to 17.3	N/A
Copper Coaxial	Yes	Yes	Yes	Yes	Yes	Yes	Yes	N/A	Yes	N/A	Yes (optional double wall for DHW)
Cupronickel Coaxial	Yes	Yes	Yes	Yes	Yes	Yes	N/A	N/A	Yes	N/A	Yes
Stainless Steel Brazed Plate Heat	N/A	N/A	N/A	GZS: 015-072 Only GZT: Yes	Load Heat Exchanger	N/A	N/A	Yes	N/A	Yes	N/A
HX Insulation	Foam Enclosed	Foam Enclosed	Foam Enclosed	Foam Enclosed	Foam Enclosed	Foam Enclosed	Foam Enclosed	Foam Enclosed	Foam Enclosed	Foam Enclosed	Foam Enclosed
Air Coil	Aluminum Micro-Channel	Aluminum Micro-Channel	Aluminum Micro-Channel	Aluminum Micro-Channel	Aluminum Micro-Channel	N/A	N/A	N/A	N/A	N/A	N/A
Desuperheater	Optional	Optional	Optional	Optional	Optional	Optional	Optional	Indirect Hot Water	Optional	Optional	N/A
Auxiliary Electric Heat	One-Piece Internal	External Close Coupled (Excluding VS006-012)	One-Piece Internal	External Close Coupled (Excluding ZS006-012)	One-Piece Internal	N/A	N/A	Internal immersion Heater	N/A	N/A	N/A
Blower	Variable Speed ECM	PSC: All ECM: All, excluding VS006-012	Variable Speed ECM	PSC: All ECM: All, excluding ZS006-012	Variable Speed ECM	N/A	N/A	N/A	N/A	N/A	N/A
Selectable CFM	Yes	Yes	Yes	Yes	Yes	N/A	N/A	N/A	N/A	N/A	N/A
Freeze Protection	Digital	Digital	Flow Switch	Digital & Flow Switch	Flow Switch	Flow Switch	Flow Switch	Digital & Flow Switch	Flow Switch	Digital	Digital
Controls	Digital	Digital	Digital	Digital	Digital	Digital	Digital	Advanced Digital	Digital	Digital	Digital
Water Fittings	Double O-ring	Double O-ring	Double O-ring	3/4" FPT - ZS006-017 1" FPT - ZS/ ZT018-072	Double O-ring	Double O-ring	Double O-ring	Double O-ring	Double O-ring - Source 1" FPT - Load	1.25" MPT	Double O-ring - Source 3/4" FPT (vented) and 1" FPT (unvented) Load
Air Handler Match	N/A	N/A	N/A	N/A	N/A	Yes	Yes	Yes	Yes	Yes	Yes
"A" Coil Match	N/A	N/A	N/A	N/A	N/A	Yes	Yes	Yes	Yes	Yes	Yes
EPIC Connected Controls Powered by myUplink	Yes	TBA	TBA	TBA	TBA	TBA	TBA	TBA	TBA	TBA	TBA



* See pages 23 - 27 for extended performance data

epic™ Now available with EPIC Connected Controls.



HYT | 2-Stage Multi-Position Vertical Packaged Unit



-  EPIC connected controls
-  Forced air heating and cooling
-  Domestic hot water assist

Warranty

Standard 10-10-5 Year Warranty

Optional Option 18 Limited Compressor and MCHX extended warranty, years 11 to 18

Other Optional Warranties available

See page 28 for more Warranty details

Installation Example

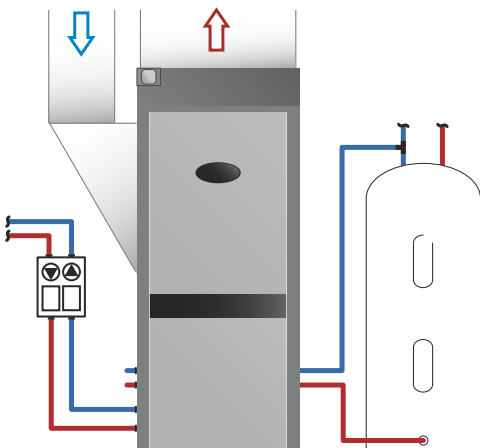

Unit Features

5 Sizes: 024, 036, 048, 060, 072

Seamless Connectivity

- Energy monitoring through EPIC Connected Controls
- Compatible with most heat pump thermostats and WiFi networks
- Intuitive, future-proofed design

All-Aluminum Micro-Channel Air Coil (MCHX)

Elastomeric compressor isolation mounting suspension

Field selectable Multi-Positional return air pattern

Optional Factory Installed soft start kit

Top discharge standard, Optional side or back discharge available on 036 - 072

Copeland UltraTech® Two-Stage Scroll Compressor

Factory supplied discharge and return duct flanges

Optional deluxe filter rack (allows 1" or 2" filters)

Composite, anti-microbial drain pan

Eye Level easy to access advanced digital controls with status light viewing window

ECM Blower Motor

Double O-Ring Water Fittings

3/4" FPT Hot Water Generator (HWG) connections

Copper or Optional Cupronickel Heat Exchanger

Optional cabinet-mounted Flow Center (YT024 excluded)



Optional cabinet-mounted Flow Center



HVS/HVT | Single or 2-Stage Compact Vertical Packaged Unit

Made to fit in tight spaces.

- Forced air heating and cooling
- Domestic hot water assist



Warranty

Standard 10-10-5 Year Warranty
Optional Option 18 Limited Compressor and MCHX extended warranty, years 11 to 18
See page 28 for more Warranty details

Installation Example

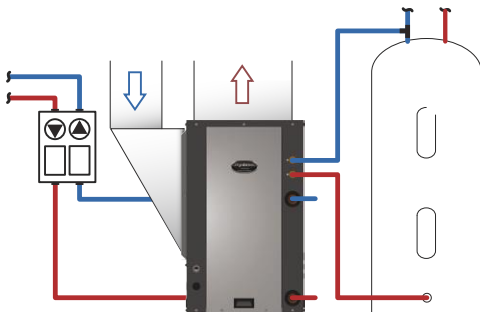

Unit Features

VS – 13 Sizes: 006, 009, 012, 015, 018, 024, 030, 036, 041, 042, 048, 060, 072

VT – 7 Sizes: 024, 030, 036, 042, 048, 060, 072

All-Aluminum Micro-Channel Air Coil (MCHX)

Elastomeric compressor isolation mounting suspension

Small foot-print cabinet with removable access panels.

High Density Foam Insulated Flat Wound Enhanced Surface Coaxial Heat Exchanger

Front plate-mounted refrigeration service ports give easy access to refrigerant circuit

Thermostatic Expansion Valve (TXV) metering for extended range of loop temperatures

VS006-015 – LG Rotary Compressor

VS018-072 – Copeland Single-Stage Scroll Compressor

VT – Copeland UltraTech® 2-Stage Scroll Compressor

Double O-Ring Water Fittings

VS – Models 006-012 come with Corrosion-proof stainless steel drain pan

VS/VT – Models 018-072 come with Composite, anti-microbial drain pan with condensate overflow protection sensor

Rugged Steel Cabinet with Removable Access Panels

Easy access control box - folds up and out for service

Digital Controls with Fault Retry and Service LED's

Optional ECM Blower Motor

VS015-072 – Standard Desuperheater with Internal Pump

VT024-072 – Standard Desuperheater with Internal Pump

Copper or Optional Cupronickel Heat Exchanger



HXT | 2-Stage Multi-Position Vertical Packaged Unit

Crafted for flexible field installation options.

- Forced air heating and cooling
- Domestic hot water assist

Warranty

Standard 10-10-5 Year Warranty

Optional Option 18 Limited Compressor and MCHX extended warranty, years 11 to 18

Other Optional Warranties available

See page 28 for more Warranty details

Installation Example

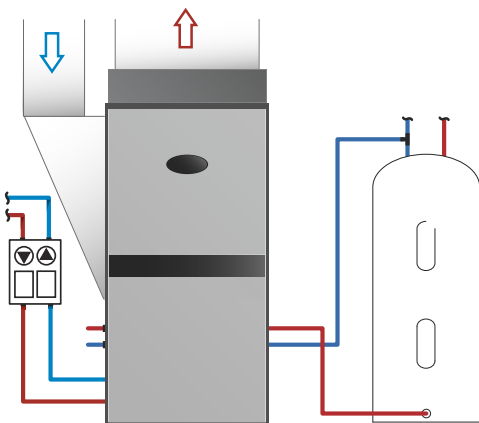

Unit Features

5 Sizes: 024, 036, 048, 060, 072

Multi-Position Cabinet (Left Return, Right Return, Upflow, Downflow Convertible)

Copeland UltraTech® 2-Stage Scroll Compressor

Factory supplied 1" thick filter rack and MERV 10 pleated throw away filter

R-410A Zero-Ozone Depletion Refrigerant

All-Aluminum Micro-Channel Air Coil (MCHX)

Composite, Anti-microbial Drain Pan

Rugged Steel Cabinet

Remote Eye-Level Mounted Digital Controls with fault retry and service LEDs

ECM Blower Motor

Standard Desuperheater with Internal Pump

Double O-Ring Water Fittings

Copper or Optional Cupronickel Heat Exchanger

NEW



HZS/HZT | Single or 2-Stage Compact Horizontal Packaged Unit

A light unit
with high
efficiencies.

- Forced air heating and cooling
- Domestic hot water assist

Warranty

Standard 10-10-5 Year Warranty

Optional Option 18 Limited Compressor and MCHX extended warranty, years 11 to 18

Other Optional Warranties available

See page 28 for more Warranty details

Installation Example

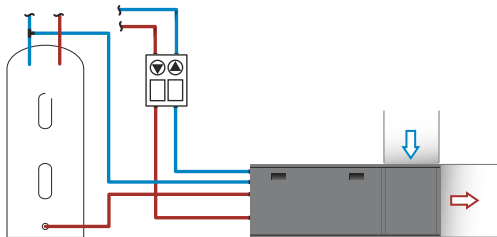

Unit Features

ZS – 13 Sizes: 006, 009, 012, 015, 017, 018, 024, 030, 036, 042, 048, 060, 072

ZT – 7 Sizes: 024, 030, 036, 042, 048, 060, 072

Field convertible side or end discharge

UL GREENGUARD certified foam insulation

Optional 1" or 2" filter rack available

All-Aluminum Micro-Channel Air Coil (MCHX)

Standard Copper Coaxial Heat Exchanger

Optional Cupronickel Coaxial Heat Exchanger or High Efficiency Stainless Steel Brazed Plate Heat Exchanger (BPHE)

ZS – Optional PSC or ECM Blow Motor

ZT – ECM Blow Motor

Optional Factory Installed soft start kit

Corrosion-proof stainless steel drain pan

ZS006-015 – LG Rotary Compressor

ZS018-072 – Copeland Single-Stage Scroll Compressor

ZT – Copeland UltraTech® 2-Stage Scroll Compressor

ZS015-072 – Standard Hot Water Generator (HWG) with Internal Pump

ZT – Standard Hot Water Generator (HWG) with Internal Pump

ZS – 3/4" FPT Water Fittings (006-017)



1" FPT Water Fittings (018-072)

ZT – 1" FPT



HCT | 2-Stage Multi-Positional Vertical Combination Unit

One unit for
forced air
and in-floor
heating.

-  Forced air heating and cooling
-  Radiant in-floor heat
-  Domestic hot water assist

Warranty

Standard 10-10-5 Year Warranty

Optional Option 18 Limited Compressor and MCHX extended warranty, years 11 to 18

Other Optional Warranties available

See page 28 for more Warranty details

Installation Example

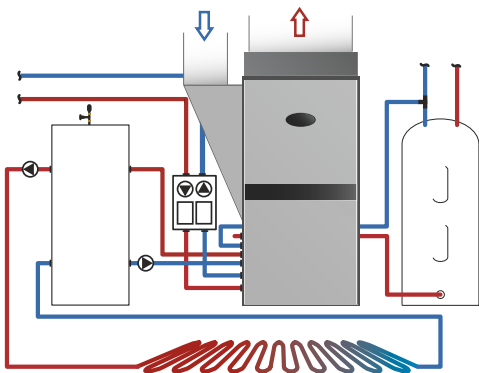

Unit Features

4 Sizes: 036, 048, 060, 072

Multi-Position Cabinet (Left Return, Right Return, Upflow, Downflow Convertible)

Copeland UltraTech® 2-Stage Scroll Compressor

Hydronic heating function

Factory supplied 1" thick filter rack and MERV 10 pleated throw away filter

R-410A Zero-Ozone Depletion Refrigerant

All-Aluminum Micro-Channel Air Coil (MCHX)

Composite, Anti-microbial Drain Pan

Rugged Steel Cabinet

Remote Mounted Controls

ECM Blower Motor



Desuperheater with Internal Pump

Copper or Optional Cupronickel Heat Exchanger



HBS/HBT | Single or 2-Stage Indoor Split Unit

Made to stand alone or as part of a dual-fuel system.

-  Forced air heating and cooling
-  Domestic hot water assist

Warranty

Standard 10-10-5 Year Warranty

Optional Option 18 Limited Compressor and MCHX extended warranty, years 11 to 18

Other Optional Warranties available

See page 28 for more Warranty details

Installation Example

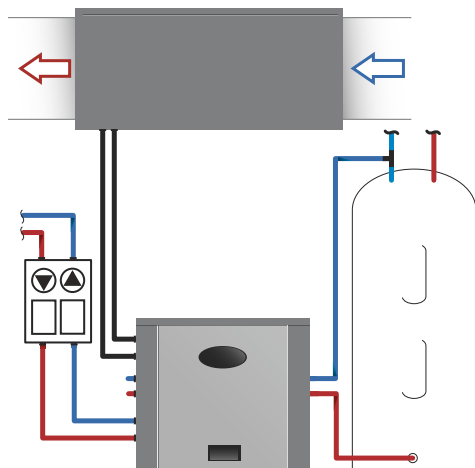

Unit Features

BS – 1 Size: 018

BT – 5 Sizes: 024, 036, 048, 060, 072

Matched multi-position air handler or A-coil

Digital controls with fault retry, service fault LED's and remote fault indication

BS018 – Copeland Single Speed Scroll Compressor

BT – Copeland UltraTech® 2-Stage Scroll Compressor

Standard Desuperheater with Internal Pump

Copper or Optional Cupronickel Heat Exchanger

Double O-Ring Water Fittings



HRT | 2-Stage Outdoor Split Unit

Made for retrofit applications where outdoor installation is required.

 Forced air heating and cooling

Warranty

Standard 10-10-5 Year Warranty

Optional Option 18 Limited Compressor and MCHX extended warranty, years 11 to 18

Other Optional Warranties available

See page 28 for more Warranty details

Installation Example

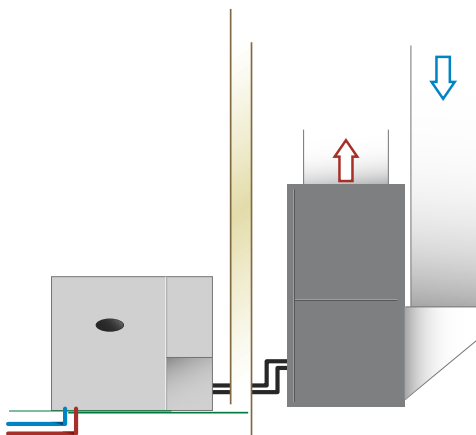

Unit Features

4 Sizes: 024, 036, 048, 060

UV Protected Outdoor Cabinet

Matched multi-position air handler or A-coil

Copeland UltraTech® 2-Stage Scroll Compressor

R-410A Zero-Ozone Depletion Refrigerant

Back-Seating Service Valves with Service Ports

All Digital Controls

Flow Center Cover

Included Outdoor Installation Kit (Flow Center Sold Separately, See Unit Accessories)

Aluminum Pipe Shield

- Pump Wiring Harness
- Hose Kit
- 90° PE Street Elbows

Built-In Freeze Protection for Pump Control

Copper coaxial water heat exchanger





The innovative design of the unit is centered on ease of installation. Shown above, the loop can easily be brought to the unit from almost any angle. Additionally, the unit could be rotated 90° counterclockwise if needed.

NEW



HWV | Variable Speed Water-to-Water Unit

One system
that does
it all!

-  Radiant in-floor heat
-  Up to 100% of domestic hot water needs
-  Forced air heating and cooling functionality

Warranty

Standard 10-10-5 Year Warranty

- Tank excluded and manufacturer's warranty applies

See page 28 for more Warranty details

Installation Example

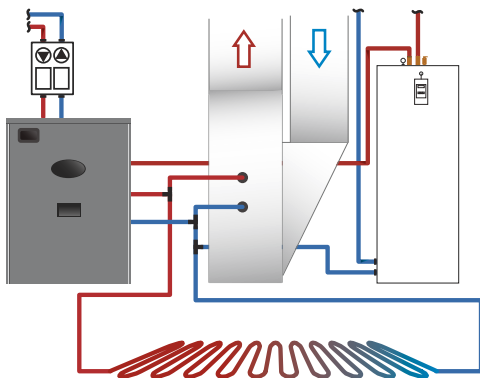

Unit Features

1 Size: 060

Copeland Variable Speed
Compressor

Double O-Ring Connections (comes
with fittings)

Variable Speed Capacity Modulation

High Temperature Output to 135°F
Leaving Load Temp

100% Domestic Water Heating
Capability

On-board Controls for Outdoor

Temperature Reset

Built-In LCD Display

Brazed Plate Heat Exchanger
Technology

Variable Speed Internal Load and
External Source Pumps

Multiple Indirect Hot Water Heater
Options: 45 gallon/65 gallon

Pressurized and non-pressurized
source pumping options: Single
pump and dual pumps

NEW



HHP | Single-Stage High Performance – High Temperature Water-to-Water Unit

The vented or unvented coax option allows for installation versatility.

- Up to 100% of domestic hot water needs
- Radiant in-floor heating
- Pool heating

Warranty

Standard 5-5-5 Warranty

See page 28 for more Warranty details

Installation Example

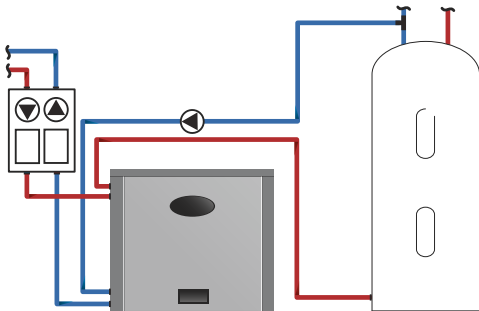

Unit Features

1 Size: 024

Single-Stage Rotary Compressor

Double O-Ring Fittings (Source Side)

3/4-inch FPT Load Connections

Standard Vented-Double Wall Load Coil with Unvented Single-Wall Option

Standard Copper Coax Source Heat Exchanger with Cupronickel Option





Foam Insulated, Enhanced Surface Coaxial Heat Exchanger

Top and all Side Panels Are Removable

HWT | 2-Stage Water-to-Water Unit



A great system for radiant in-floor heating needs.

-  Radiant in-floor heating
-  Domestic hot water assist
-  Forced air heating and cooling functionality
-  Pool heating



Warranty

Standard 10-10-5 Year Warranty

Optional Option 18 Limited Compressor and MCHX extended warranty, years 11 to 18

Other Optional Warranties available

See page 28 for more Warranty details

Installation Example

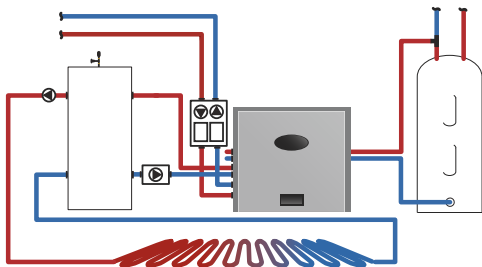

Unit Features

3 Sizes: 036, 048, 060

Advanced Elastomeric compressor
isolation mounting suspension

Digital controls with fault retry,
service fault LED's and remote fault
indication

Standard Copper or optional
Cupronickel heat exchanger [source
side] / Copper [load side]

High efficiency Copeland UltraTech®
scroll compressor

Rugged steel cabinet

Optional Hot Water Generator



Double O-ring connections (source
side)

1" FPT connections (load side)



HWS | Single-Stage and Dual Compressor Water-to-Water Unit

A lighter and more efficient water-to-water heat pump.

-  Radiant in-floor heating
-  Domestic hot water assist

Warranty

Standard 10-10-5 Year Warranty

Optional Option 18 Limited Compressor and MCHX extended warranty, years 11 to 18

Other Optional Warranties available

See page 28 for more Warranty details

Installation Example

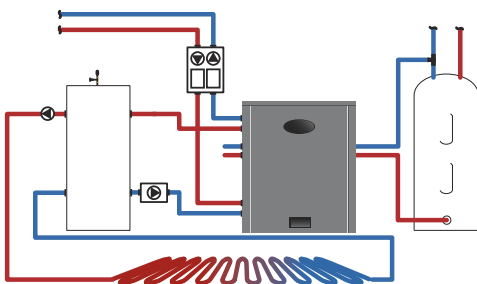

Unit Features

5 Sizes: 036, 048, 060, 072, 084

Copeland Single Stage Scroll Compressors

1-1/4" load side connections

1-1/4" source side connections (brazed plate for closed loop applications) or secondary heat exchanger available for open loop systems

Front, Top & Rear Access

Electronic Controls with Safety Lock Out

High and Low Access Valves Ports

Thermostatic Expansion Valve

R-410A Zero-Ozone Depletion Refrigerant

Stainless Brazed Plate Heat Exchangers (BPHE)

Standard Desuperheater with Internal Pump



Enertech DX Series, R410A, Multi-Position Air Handlers

AHRI match with Hydron Module Split Systems

6 sizes: 1.5 (018), 2 (024), 3 (036), 4 (048), 5 (060), and 6 (072) ton

Multi-Positional Applications (upflow, downflow, horizontal)

Variable Speed ECM Fan Motor

Factory Installed TXV (for cooling)

Factory installed 75VA Transformer with Circuit Breaker

All-Aluminum Micro-channel Air Coil

“Easy glide” slide out “A” Coil assembly for downflow applications

Easy to remove access panels

Easy to remove thermostat and control board “Snap Lock” mount

Galvanized, pre-painted steel for quality and durability

Corrosion proof plastic drain pan with primary and secondary connections

“Easy glide” slide out blower assembly

Closed cell insulated cabinet

2 piece cabinet - cased coil and blower

Modular Design allows flexibility when installing in tight spaces, which removes the need for home or building structure modifications

Optional “Plug-N-Play” Field Installed Electric Heater

Optional Filter Rack

5 Year Parts and 5 Year Service Labor Allowance warranty

Optional extended warranty options available



Enertech DX Series, R410A, Cased Coils

AHRI match with Hydron Module Split Systems

6 sizes: 1.5 (018), 2 (024), 3 (036), 4 (048), 5 (060), and 6 (072) ton

Multi-Positional Applications

Factory Installed TXV (for cooling)

All-Aluminum Micro-channel Air Coil

Galvanized, pre-painted steel for quality and durability

Corrosion proof plastic drain pan with primary and secondary connections

“Easy glide” slide out coil assembly

Closed cell insulated cabinet

5 Year Parts and 5 Year Service Labor Allowance warranty

Optional extended warranty options available

Air Handlers and Coils

MP Series Multi-Position Hydronic Air Handlers

Optimized for use with Hydron Module water-to-water heat pumps

Multi-position air pattern ships in upflow configuration

Field convertible to downflow and horizontal configuration (downflow kit required for downflow operation)

Variable-speed ECM fan motor

Corrosion-proof plastic drain pan with primary and secondary drain connections

Oversized copper tube/aluminum fin "A" coil for maximum efficiency

Copper sweat water connections

Factory-installed R-410a TXV

Narrow width (25" maximum) for small closet installations

Slide-out blower assembly

Optional downflow kit

Optional field-installed internal electric heat with circuit breakers

Optional filter rack with standard size 1" filters

Consult warranty page for coverage details



AC Series Hydronic Uncased "A" Coils

Single coil for both chilled water and hot water

Designed for 100°F to 120°F water in heating operation

Optimized for use with Hydron Module water-to-water heat pumps

Copper sweat water connections

Corrosion-proof plastic drain pan with primary and secondary drain connections

Consult warranty page for coverage details



MC Series Hydronic Cased "A" Coils

Same features as the AC Hydronic "A" Coil, but enclosed in a rigid cabinet for easy installation, especially on retrofit and dual-fuel applications.

Unit Accessories



Loop Pipe

- Pre-assembled U-bend coils
- Straight pipe
- Coiled pipe
- Pond spaced coils



Fittings

- | | |
|---------|-----------|
| Headers | Couplings |
| Elbows | Tees |
| Unions | Bushings |

Flow Centers, Insulated Pumps & Replacement Pumps

NEW! Alpha2 Insulated Pump

Grundfos Alpha2 26-99 Pump

Powder coated sheet metal cabinet with expanding closed cell urethane insulation to reduce condensation in chilled water operation

1" FPT Isolation Valves

Variable Speed ECM motor

Push Button Programming

Three defined proportional pressure curve settings

Three defined constant pressure curve settings



Composite/Brass Valve Double O-ring Fittings

Double O-ring fittings or 1" NPT connections

Front flush ports

Foam insulated cabinet stops condensation

High impact polystyrene cabinet will not rust

Fully assembled and leak tested



Non-Pressurized

Double O-ring fittings or 1" NPT connections

Foam insulated cabinet stops condensation

Fully assembled and leak tested

Variable-speed available



Variable-Speed

Grundfos UPM-XL pumps

ECM motor technology

1" brass flush valves

Built-in control



Hose Kits & Loop Add-Ons

GeoPrime reservoir tanks

Geo Booster

Pressure batteries



Thermostats



Sensi Touch Wi-Fi

HD color touchscreen

Can change temperature setting based on GPS location

Smart home compatible

Easy-click, no screwdriver terminals



Sensi Wi-Fi

Extreme temperature notification

7 day programmable

Remote access and contractor contact info with smartphone app

4 Heat / 2 Cool stages

Keypad lockout

Multi thermostat control

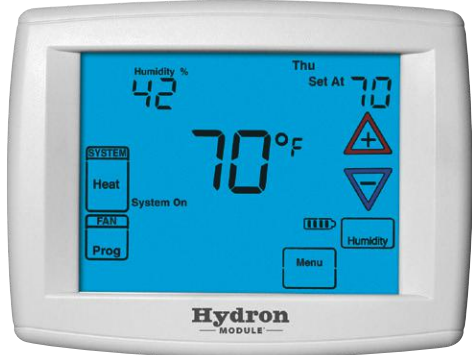

Touch Screen

Single-stage / multi-stage

Programmable (7-day, 5/1/1 day) or non-programmable

Hard wired or battery powered with power stealing assist

Remote sensing indoor or outdoor and at the thermostat

Programmable fan with comfort circulator fan option

Enhanced dehumidification control

Automatic daylight savings option

Flow-through humidifier water-saving feature — up to 50%

Large, 12 square inch display with 10-second backlight

Exclusive energy saving feature during peak A/C demand periods

Dual-fuel heat pump logic program requires no outdoor sensor



Non-Programmable

Large easy to read screen with a bright backlit display

Adjustable temperature set point min. / max. limits

Auto changeover

Dual-fuel control

Keypad lockout

4 Heat / 2 Cool stages

URD

Nylon blade shaft notched to indicate blade position

Male crimped end to ease installation process

Open and closed LEDs indicate blade position

Nylon shaft provides thermal barrier to eliminate condensation

Integrated seal eliminates loose gasket material

Integrated door seal provides 97% shut off to 1" W.C.

Min/Max adjustable closed set points



SID [SLIP-IN-DAMPER]

Allows for up to 20 SID's on one EWC control panel

More sizes available than any other component

Optional end switch for additional interface



UZC : COMPATIBLE WITH ALL HVAC SYSTEMS UP TO 4 STAGES OF HEAT AND 2 STAGES OF COOL

Auto-changeover and fan control from any zone

Computer watchdog circuitry prevents lock-ups from power failures and power interruptions

Controls up to 20 zones

LED display for complete diagnostic system readout

Adjustable heating and cooling limits to protect equipment



BMPLUS : COMPATIBLE WITH ALL HVAC SYSTEMS UP TO 3 STAGES OF HEAT AND 2 STAGES OF COOL

Dual-fuel kits not required

One zone mode

Automatic changeover from any zone

Computer watchdog circuit to ensure operation

Supply air sensor included

Optional outdoor air sensor



ND

Nylon blade shaft notched to indicate blade position

Heavy gauge extruded aluminum frame

Nylon blade bushings allow for smooth, quiet operation

Open and closed LEDs indicate blade position

Nylon shaft provides thermal barrier to eliminate condensation

Overlapping blades provides 97% shut off up to 1" W.C.

Custom and odd sizes available



NCM : SINGLE STAGE, DUAL-FUEL AND HEAT PUMP COMPATIBLE UP TO 3 ZONES

Computer watchdog circuit

Auto-changeover from any zone

LED display for complete system read out

Supply air sensor to protect equipment

Adjustable purge time



Unit Accessories

Auxiliary Heaters

INTERNAL AUXILIARY ELECTRIC HEATER

Single piece design (no separately mounted control box)

Heater staging (YT, XT & CT Series)

Low voltage harness for direct connection to relay board

Automatic high limit and auxiliary limit switches for over temperature protection

Internal circuit breakers

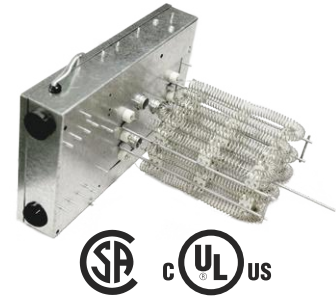

CLOSE COUPLED DUCT HEATER FEATURES:

Single piece design (no separately mounted control box)

Heater staging (VS/VT & ZS/ZT Series)

Low voltage harness for direct connection to relay board

Internal circuit breakers

Automatic high limit and auxiliary limit switches for over temperature protection

Downstream installation not required like external duct heater.

Easy installation

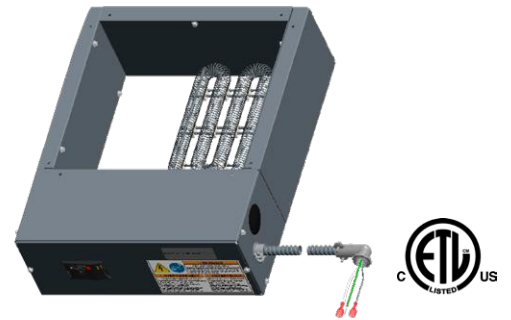

Unit Accessories

Filters

ELECTRONIC DYNAMIC® FILTER

High efficiency electronic air cleaners

MERV equivalency rating of 13

Disposable low static polarized media

Media contains activated charcoal

Sizes: 16"x 20"x 1" up to 28"x 34"x 1"

(see price book for actual sizes and compatibility)



ELECTROSTATIC FILTERS

Self charging media

3 filtration layers

Sizes: 16"x 20"x 1" up to 38"x 36"x 1"

(see price book for actual sizes and compatibility)

Washable filter

Lifetime warranty

Unit Performance Data

Model	Type	Cooling with PSC Blower		Heating with PSC Blower		Cooling with ECM Blower Option		Heating with ECM Blower Option		Dimensional Data			Height with Control Box	Unit Weight (lbs)
		BTU	EER	BTU	COP	BTU	EER	BTU	COP	Height	Width	Depth		
VS – Single-Stage Compact Vertical Packaged – Water-to-Air – PLEASE NOTE PSC AND ECM BLOWER LISTINGS														
VS006	Ground Water	7,800	25.8	7,000	4.6	–	–	–	–	30"	21.5"	21.5"	–	167
	Ground Loop	7,200	18.6	5,600	3.7	–	–	–	–					
VS006 PSC 115V, 265V Only	Ground Water	7,900	24.0	7,100	4.5	–	–	–	–	30"	21.5"	21.5"	–	167
	Ground Loop	7,200	17.7	5,500	3.5	–	–	–	–					
VS009	Ground Water	11,900	22.1	10,600	4.4	–	–	–	–	30"	21.5"	21.5"	–	234
	Ground Loop	10,900	17.4	8,500	3.6	–	–	–	–					
VS012	Ground Water	13,400	24.1	12,100	4.3	–	–	–	–	30"	21.5"	21.5"	–	234
	Ground Loop	11,900	18.1	9,400	3.6	–	–	–	–					
VS015	Ground Water	17,500	28.8	14,600	5.1	17,400	31.6	14,400	5.4	37.3"	22.5"	22.5"	–	234
	Ground Loop	16,000	19.8	11,600	4.1	16,000	22.3	11,500	4.3					
VS018	Ground Water	23,200	27.5	20,100	5.0	23,200	30.5	19,600	5.3	37.3"	22.5"	22.5"	–	260
	Ground Loop	21,400	20.0	16,300	3.9	21,700	22.2	15,400	4.0					
VS024	Ground Water	28,100	26.0	24,200	4.9	29,400	29.5	24,000	5.1	37.3"	22.5"	22.5"	–	265
	Ground Loop	26,000	19.7	19,400	4.0	27,000	21.6	19,300	4.2					
VS030	Ground Water	31,000	23.4	28,700	4.7	34,000	27.5	29,200	5.1	37.3"	22.5"	22.5"	–	285
	Ground Loop	30,100	18.5	22,300	3.9	31,400	20.4	23,200	4.2					
VS036	Ground Water	40,500	23.5	37,600	4.6	41,600	25.5	36,900	4.8	37.3"	22.5"	22.5"	–	310
	Ground Loop	37,800	18.0	30,200	3.9	38,800	19.2	29,600	3.9					
VS041	Ground Water	41,400	22.3	38,900	4.1	43,000	23.6	39,200	4.4	37.3"	22.5"	22.5"	–	310
	Ground Loop	38,700	17.1	31,100	3.6	39,800	17.8	31,200	3.7					
VS042	Ground Water	46,700	24.4	39,200	4.7	47,700	28.4	38,300	5.0	41.0"	25.0"	27.9"	–	357
	Ground Loop	43,600	18.6	32,000	3.8	44,400	21.2	31,100	4.1					
VS048	Ground Water	53,400	22.6	48,100	4.4	54,900	26.4	47,500	4.8	41.0"	25.0"	27.9"	–	360
	Ground Loop	50,500	17.6	39,600	3.6	51,600	20.1	38,700	3.9					
VS060	Ground Water	63,300	21.3	58,700	4.3	65,000	22.8	58,100	4.6	41.0"	25.0"	27.9"	–	375
	Ground Loop	60,000	16.9	46,900	3.6	61,500	18.2	46,300	3.8					
VS072	Ground Water	74,600	19.1	66,500	4.0	75,600	19.7	66,200	4.1	41.0"	25.0"	27.9"	–	367
	Ground Loop	70,100	15.1	53,200	3.3	70,900	15.7	52,900	3.4					
Model	Type	Cooling BTU				Heating BTU				Dimensional Data			Height with Control Box	Unit Weight (lbs)
		Full Load	EER	Part Load	EER	Full Load	COP	Part Load	COP	Height	Width	Depth		
VT – Two-Stage Compact Vertical Packaged – Water-to-Air														
VT024	Ground Water	27,600	23.8	19,900	28.4	23,900	4.6	16,800	4.4	37.3"	22.5"	22.5"	–	248
	Ground Loop	25,800	18.6	19,300	24.2	19,400	4.0	14,800	3.8					
VT030	Ground Water	34,100	23.1	26,500	30.4	30,300	4.6	22,100	4.7	37.3"	22.5"	22.5"	–	265
	Ground Loop	32,200	18.4	25,500	25.8	24,300	3.8	20,000	4.2					
VT036	Ground Water	40,000	22.8	29,500	29.8	36,900	4.6	25,700	4.7	37.3"	22.5"	22.5"	–	271
	Ground Loop	37,400	17.7	28,500	25.2	29,500	3.9	22,900	4.2					
VT042	Ground Water	49,200	24.0	36,500	31.4	40,100	4.6	28,800	4.7	41.0"	22.5"	27.9"	–	357
	Ground Loop	45,900	18.5	35,100	26.0	32,400	3.9	25,500	4.2					
VT048	Ground Water	54,700	24.5	40,600	33.0	46,900	4.6	33,600	4.9	41.0"	25.0"	27.9"	–	361
	Ground Loop	51,300	18.9	39,200	27.2	38,300	3.9	30,200	4.3					
VT060	Ground Water	64,200	22.0	48,300	26.5	57,500	4.5	41,300	4.7	41.0"	25.0"	27.9"	–	373
	Ground Loop	60,900	17.6	46,500	23.6	46,300	3.8	36,600	4.2					
VT072	Ground Water	72,800	19.7	56,900	24.5	64,700	4.1	49,600	4.3	41.0"	25.0"	27.9"	–	375
	Ground Loop	68,900	15.8	55,300	21.1	51,800	3.4	44,000	3.9					
YT – Vertical Packaged – Water-to-Air														
YT024	Ground Water	29,200	25.7	22,200	33.6	23,400	5.3	17,500	5.5	46.0"	23.0"	26.5"	53.25"	310
	Ground Loop	27,100	19.9	21,400	28.2	19,000	4.3	15,200	4.8					
YT036	Ground Water	44,300	27.0	32,700	37.4	37,500	5.5	26,600	5.8	54.0"	25.4"	30.5"	61.25"	405
	Ground Loop	41,200	20.9	31,500	31.3	29,100	4.5	23,300	5.1					
YT048	Ground Water	57,100	26.2	44,100	35.3	49,500	5.2	35,900	5.5	54.0"	25.4"	30.5"	61.25"	450
	Ground Loop	53,300	20.2	42,600	29.6	39,900	4.3	32,000	4.9					
YT060	Ground Water	68,700	24.8	51,900	33.4	61,700	4.9	42,900	5.2	58.4"	25.4"	30.5"	65.65"	475
	Ground Loop	64,300	19.3	50,000	28.0	49,200	4.1	37,700	4.6					
YT072	Ground Water	77,600	23.2	60,800	29.5	71,100	4.6	52,100	4.8	58.4"	25.4"	30.5"	65.65"	480
	Ground Loop	71,900	18.0	58,500	24.8	56,200	3.8	45,800	4.4					
XT – Vertical Packaged – Water-to-Air														
XT024	Ground Water	29,600	26.9	22,400	35.0	24,700	5.2	18,500	5.4	56.1"	28"	32.2"	62.5"	415
	Ground Loop	27,200	20.3	21,400	29.1	19,800	4.3	16,600	4.8					
XT036	Ground Water	42,200	24.0	31,100	32.6	37,000	5.1	26,000	5.2	56.1"	28"	32.2"	62.5"	420
	Ground Loop	38,900	18.3	29,900	27.0	29,200	4.2	23,200	4.6					
XT048	Ground Water	53,100	22.1	39,400	29.4	47,400	4.6	33,700	4.9	56.1"	28"	32.2"	62.5"	433
	Ground Loop	49,000	17.1	37,400	24.1	38,200	3.9	29,700	4.3					
XT060	Ground Water	67,700	22.4	50,800	29.8	60,000	4.5	43,300	4.8	60.1"	28"	32.2"	66.5"	466
	Ground Loop	63,000	17.8	49,000	24.9	47,700	3.7	38,600	4.3					
XT072	Ground Water	75,600	21.1	59,200	26.9	70,300	4.3	52,800	4.6	60.1"	28"	32.2"	66.5"	479
	Ground Loop	71,100	17.1	57,500	23.0	55,900	3.6	46,700	4.1					

Unit Performance Data

Model	Type	Cooling				Heating				Dimensional Data			Ref. Conn. Liq. Suct.	Unit Weight (lbs)	
		Full Load	EER	Part Load	EER	Full Load	COP	Part Load	COP	Height	Width	Depth			
BS — Single-Stage Indoor Split — Water-to-Air													Ref. Conn. Liq. Suct.		
BS018	Ground Water	24,300	31.60	—	—	18,700	5.00	—	—	21"	26"	26"	3/8"	5/8"	190
	Ground Loop	22,200	22.20	—	—	14,400	3.90	—	—						
BT — Two-Stage Indoor Split — Water-to-Air													Ref. Conn. Liq. Suct.		
BT024	Ground Water	28,900	26.90	22,300	33.30	23,900	4.70	17,900	4.70	21"	26"	26"	3/8"	5/8"	190
	Ground Loop	26,300	20.40	21,500	27.80	18,800	3.90	15,900	4.30						
BT036	Ground Water	39,700	24.80	30,600	35.00	37,200	4.70	26,700	4.80	21"	26"	26"	3/8"	5/8"	201
	Ground Loop	36,900	19.30	29,300	28.90	29,000	3.90	23,500	4.30						
BT048	Ground Water	54,200	25.40	41,500	34.60	50,800	4.80	36,700	5.10	21"	26"	26"	3/8"	3/4"	226
	Ground Loop	50,300	19.50	39,600	28.60	41,000	3.90	32,900	4.50						
BT060	Ground Water	65,700	23.50	50,400	30.10	58,300	4.40	42,700	4.60	21"	26"	26"	3/8"	7/8"	229
	Ground Loop	61,100	18.20	48,400	25.20	46,800	3.80	38,200	4.20						
BT072	Ground Water	70,700	21.10	58,100	26.80	70,500	4.10	52,900	4.40	21"	26"	26"	3/8"	7/8"	244
	Ground Loop	68,400	16.90	56,000	22.40	57,300	3.50	47,700	4.00						
RT — Outdoor Split — Water-to-Air													Ref. Conn. Liq. Suct.		
RT024	Ground Water	—	—	—	—	—	—	—	—	23.4"	32"	28.8"	3/8"	7/8"	180
	Ground Loop	25,800	16.90	20,700	22.50	18,700	3.60	15,600	3.90						
RT036	Ground Water	—	—	—	—	—	—	—	—	23.4"	32"	28.8"	3/8"	7/8"	225
	Ground Loop	37,500	18.50	29,700	27.20	28,300	4.10	22,500	4.60						
RT048	Ground Water	—	—	—	—	—	—	—	—	23.4"	32"	28.8"	3/8"	7/8"	270
	Ground Loop	49,800	17.90	38,800	25.00	38,500	3.70	30,800	4.30						
RT060	Ground Water	—	—	—	—	—	—	—	—	23.4"	32"	28.8"	1/2"	1 1/8"	270
	Ground Loop	60,500	17.40	47,700	24.30	46,200	3.60	36,200	4.10						
CT — Multi-Position Vertical Combination — Water-to-Air													Height with Control Box		
CT036	Ground Water	41,700	23.5	30,400	31.9	36,700	5.0	25,600	5.2	56.1"	28"	32.2"	62.5"	420	
	Ground Loop	38,600	18.3	29,100	26.8	28,600	4.1	22,400	4.6						
CT048	Ground Water	53,100	21.8	39,400	29.4	46,700	4.6	33,700	4.9	56.1"	28"	32.2"	62.5"	435	
	Ground Loop	49,000	17.1	37,400	24.1	38,000	3.9	29,700	4.3						
CT060	Ground Water	65,600	20.8	49,200	27.6	60,000	4.3	43,400	4.7	60.1"	28"	32.2"	66.5"	535	
	Ground Loop	61,000	16.6	47,400	23.4	47,900	3.7	38,700	4.2						
CT072	Ground Water	73,400	19.3	57,600	24.1	69,400	4.1	51,500	4.3	60.1"	28"	32.2"	66.5"	550	
	Ground Loop	68,800	15.6	55,600	20.8	56,000	3.5	45,800	3.9						
Model	Type	Cooling with PSC Blower		Heating with PSC Blower		Cooling with ECM Blower Option		Heating with ECM Blower Option		Dimensional Data			Unit Weight (lbs)		
		BTU	EER	BTU	COP	BTU	EER	BTU	COP	Height	Width	Depth			
ZS — Single Stage Compact Horizontal Packaged — Water-to-Air (PLEASE NOTE PSC AND ECM BLOWER LISTINGS)															
ZS006 208/230V ONLY	Water Loop	6,500	14.6	7,800	5.2	—	—	—	—	12.0"	20.0"	40.0"	Add 2.4" to width w/ filter rack	140	
	Ground Water	7,600	23.2	6,400	4.3	—	—	—	—						
	Ground Loop	6,900	17.1	5,200	3.5	—	—	—	—						
ZS006 265/115V ONLY	Water Loop	6,200	13.9	7,400	4.9	—	—	—	—	12.0"	20.0"	40.0"	Add 2.4" to width w/ filter rack	140	
	Ground Water	7,200	22	6,100	4.1	—	—	—	—						
	Ground Loop	6,500	16.2	5,000	3.3	—	—	—	—						
ZS009 208/230V ONLY	Water Loop	9,200	14.3	11,700	4.9	—	—	—	—	12.0"	20.0"	40.0"	Add 2.4" to width w/ filter rack	140	
	Ground Water	10,500	22.9	9,500	4.2	—	—	—	—						
	Ground Loop	9,600	16.7	7,500	3.5	—	—	—	—						
ZS009 265/115V ONLY	Water Loop	8,700	13.6	11,100	4.7	—	—	—	—	12.0"	20.0"	40.0"	Add 2.4" to width w/ filter rack	140	
	Ground Water	10,000	21.7	9,000	4.0	—	—	—	—						
	Ground Loop	9,200	15.9	7,100	3.3	—	—	—	—						
ZS012	Water Loop	11,000	12.5	13,600	4.3	—	—	—	—	12.0"	20.0"	40.0"	Add 2.4" to width w/ filter rack	140	
	Ground Water	12,400	18.7	11,700	3.7	—	—	—	—						
	Ground Loop	11,300	14.1	9,500	3.2	—	—	—	—						
ZS015 BPHE	Water Loop	14,600	16.3	17,100	5.4	14,600	17.3	16,700	5.5	17.0"	21.0"	40.0"	Add 2.4" to width w/ filter rack	173	
	Ground Water	—	—	—	—	—	—	—	—						
	Ground Loop	15,300	19.2	11,100	3.8	15,200	20.3	10,900	3.9						
ZS015 COAX	Water Loop	14,000	14.7	17,700	5.6	13,500	14.7	17,800	5.7	17.0"	21.0"	40.0"	Add 2.4" to width w/ filter rack	173	
	Ground Water	16,100	24.4	14,300	4.7	15,600	24.9	14,300	4.8						
	Ground Loop	14,500	17.1	11,300	3.9	14,200	17.6	11,200	3.9						
ZS017 BPHE	Water Loop	17,000	15.8	21,000	5.3	17,300	17.4	20,400	5.6	17.0"	21.0"	40.0"	Add 2.4" to width w/ filter rack	173	
	Ground Water	—	—	—	—	—	—	—	—						
	Ground Loop	18,300	18.6	13,400	3.7	18,100	20.5	13,000	3.8						
ZS017 COAX	Water Loop	16,900	14.7	20,900	5.3	17,000	15.6	20,600	5.5	17.0"	21.0"	40.0"	Add 2.4" to width w/ filter rack	173	
	Ground Water	19,200	22.5	16,900	4.5	19,400	24.9	16,700	4.7						
	Ground Loop	17,900	17.1	13,700	3.7	17,800	18.2	13,500	3.9						



Model	Type	Cooling with PSC Blower		Heating with PSC Blower		Cooling with ECM Blower Option		Heating with ECM Blower Option		Dimensional Data			Unit Weight (lbs)	
		BTU	EER	BTU	COP	BTU	EER	BTU	COP	Height	Width	Depth		
ZS018 BPHE	Water Loop	19,400	15.3	23,000	5.0	19,900	17.3	22,600	5.4	19.2"	21.7"	52"	Add 2.4" to width w/ filter rack	230
	Ground Water	–	–	–	–	–	–	–	–					
	Ground Loop	20,500	18.2	14,400	3.6	20,800	20.5	14,200	3.8					
ZS018 COAX	Water Loop	18,500	13.2	23,400	4.8	19,100	15.4	21,900	5.5	19.2"	21.7"	52"	Add 2.4" to width w/ filter rack	230
	Ground Water	20,900	20.7	18,600	4.2	21,400	26.0	17,500	4.7					
	Ground Loop	19,400	15.5	14,800	3.5	20,100	18.7	14,100	3.7					
ZS024 BPHE	Water Loop	24,100	15.8	29,700	5.0	25,000	17.9	29,300	5.6	19.2"	21.7"	52"	Add 2.4" to width w/ filter rack	236
	Ground Water	–	–	–	–	–	–	–	–					
	Ground Loop	25,200	18.7	18,600	3.7	26,100	21.5	18,600	3.9					
ZS024 COAX	Water Loop	24,600	14.9	29,300	4.9	25,300	16.9	28,500	5.5	19.2"	21.7"	52"	Add 2.4" to width w/ filter rack	236
	Ground Water	27,400	22.9	23,700	4.3	27,900	26.3	22,900	4.8					
	Ground Loop	25,700	17.4	18,500	3.6	26,200	19.6	18,000	3.9					
ZS030 BPHE	Water Loop	29,000	16.2	33,300	5.3	29,500	17.5	33,000	5.7	19.2"	21.7"	52"	Add 2.4" to width w/ filter rack	245
	Ground Water	–	–	–	–	–	–	–	–					
	Ground Loop	30,300	19.1	21,900	3.7	30,700	20.7	21,500	4.0					
ZS030 COAX	Water Loop	28,400	15.3	33,500	5.3	27,800	16.2	32,200	5.5	19.2"	21.7"	52"	Add 2.4" to width w/ filter rack	245
	Ground Water	31,800	23.4	27,900	4.5	30,900	24.6	26,300	4.7					
	Ground Loop	29,700	17.7	22,900	3.6	29,000	18.8	21,700	3.8					
ZS036 BPHE	Water Loop	35,900	15.6	43,400	4.9	36,800	16.8	43,300	5.3	21.2"	21.7"	56"	Add 2.4" to width w/ filter rack	263
	Ground Water	–	–	–	–	–	–	–	–					
	Ground Loop	37,600	18.1	27,800	3.7	38,400	19.5	27,600	4.0					
ZS036 COAX	Water Loop	35,100	15.4	43,800	4.9	35,300	16.0	42,600	5.1	21.2"	21.7"	56"	Add 2.4" to width w/ filter rack	263
	Ground Water	39,500	24.1	34,800	4.4	39,500	24.7	33,600	4.6					
	Ground Loop	36,600	17.9	28,300	3.7	37,200	18.8	27,500	3.9					
ZS042 BPHE	Water Loop	41,700	16.9	50,400	5.4	42,500	17.7	49,600	5.4	21.2"	21.7"	56"	Add 2.4" to width w/ filter rack	290
	Ground Water	–	–	–	–	–	–	–	–					
	Ground Loop	43,400	19.8	32,800	3.9	44,100	21.1	32,200	4.1					
ZS042 COAX	Water Loop	39,500	15.4	47,900	5.2	39,100	16.4	46,300	5.0	21.2"	21.7"	56"	Add 2.4" to width w/ filter rack	290
	Ground Water	44,200	23.7	38,900	4.5	43,700	25.6	37,500	4.5					
	Ground Loop	41,100	17.9	31,700	3.7	40,700	19.2	30,200	3.8					
ZS048 BPHE	Water Loop	46,800	15.4	59,300	4.6	48,100	16.3	58,100	4.9	21.2"	21.7"	56"	Add 2.4" to width w/ filter rack	293
	Ground Water	–	–	–	–	–	–	–	–					
	Ground Loop	48,500	17.8	38,500	3.6	50,400	19.1	37,800	3.8					
ZS048 COAX	Water Loop	46,600	14.7	57,100	4.7	47,300	15.1	56,300	4.9	21.2"	21.7"	56"	Add 2.4" to width w/ filter rack	293
	Ground Water	52,100	22.4	46,800	4.2	52,900	22.6	45,600	4.3					
	Ground Loop	48,600	17.0	37,800	3.5	49,300	17.4	36,200	3.6					
ZS060 BPHE	Water Loop	58,400	15.4	75,700	4.9	59,300	17.0	74,700	5.3	21.2"	24"	61"	Add 2.4" to width w/ filter rack	303
	Ground Water	–	–	–	–	–	–	–	–					
	Ground Loop	60,500	17.8	49,200	3.8	60,700	19.5	48,200	4.0					
ZS060 COAX	Water Loop	56,400	14.5	72,800	4.7	53,500	15.0	71,000	4.9	21.2"	24"	61"	Add 2.4" to width w/ filter rack	303
	Ground Water	62,000	21.0	59,600	4.2	60,500	22.3	58,600	4.3					
	Ground Loop	57,000	16.1	48,400	3.5	57,000	17.5	46,200	3.6					
ZS072 BPHE	Water Loop	68,600	15.1	88,400	4.6	69,700	15.5	88,400	4.7	21.2"	24"	61"	Add 2.4" to width w/ filter rack	312
	Ground Water	–	–	–	–	–	–	–	–					
	Ground Loop	70,600	17.2	57,400	3.5	72,100	17.7	56,600	3.7					
ZS072 COAX	Water Loop	66,600	13.4	85,300	4.3	68,500	13.7	84,200	4.3	21.2"	24"	61"	Add 2.4" to width w/ filter rack	312
	Ground Water	74,200	19.1	69,000	3.8	75,600	19.8	68,900	3.9					
	Ground Loop	70,200	15.3	56,200	3.2	71,200	15.7	56,200	3.3					

Model	Type	Cooling BTU				Heating BTU				Dimensional Data			Unit Weight (lbs)
		Full Load	EER	Part Load	EER	Full Load	COP	Part Load	COP	Height	Width	Depth	

ZT — Two Stage Compact Horizontal Packaged — Water-to-Air

ZT024 BPHE	Water Loop	25,600	17.0	18,700	19.3	30,000	5.5	21,300	6.0	19.2"	21.7"	52"	Add 2.4" to width w/filter rack	236
	Ground Water	–	–	–	–	–	–	–	–					
	Ground Loop	26,800	19.8	20,700	28.8	18,100	4.0	14,900	4.3					
ZT024 COAX	Water Loop	25,300	15.9	18,200	17.4	28,800	5.2	21,000	5.6	19.2"	21.7"	52"	Add 2.4" to width w/filter rack	236
	Ground Water	28,200	23.7	20,800	29.7	22,900	4.6	16,600	4.6					
	Ground Loop	26,400	18.3	20,000	25.0	18,300	3.9	14,500	4.1					
ZT030 BPHE	Water Loop	30,600	15.4	22,800	17.4	36,000	5.0	26,100	5.3	19.2"	21.7"	52"	Add 2.4" to width w/filter rack	245
	Ground Water	–	–	–	–	–	–	–	–					
	Ground Loop	32,000	18.0	24,800	24.9	22,600	3.7	18,700	4.0					

Unit Performance Data

Model	Type	Cooling BTU				Heating BTU				Dimensional Data			Unit Weight (lbs)	
		Full Load	EER	Part Load	EER	Full Load	COP	Part Load	COP	Height	Width	Depth		
NEW ZT030 COAX	Water Loop	30,200	15.1	22,000	16.2	34,800	5.1	26,200	5.3	19.2"	21.7"	52"	Add 2.4" to width w/filter rack	245
	Ground Water	32,600	21.6	24,700	26.5	28,800	4.5	21,400	4.5					
	Ground Loop	31,500	17.5	23,900	22.7	23,300	3.7	19,300	4.0					
ZT036 BPHE	Water Loop	36,500	17.0	26,100	19.5	43,300	5.3	30,800	6.0	21.2"	21.7"	56"	Add 2.4" to width w/filter rack	263
	Ground Water	-	-	-	-	-	-	-	-					
	Ground Loop	38,200	19.9	28,900	29.8	27,600	4.1	21,200	4.4					
ZT036 COAX	Water Loop	35,100	15.5	25,700	18.0	42,300	5.0	31,000	5.7	21.2"	21.7"	56"	Add 2.4" to width w/filter rack	263
	Ground Water	39,400	23.6	29,100	31.8	34,000	4.6	24,400	4.8					
	Ground Loop	36,700	17.9	28,100	26.6	27,100	3.8	22,000	4.3					
ZT042 BPHE	Water Loop	41,000	16.5	30,400	17.5	48,400	4.6	35,200	5.0	21.2"	21.7"	56"	Add 2.4" to width w/filter rack	280
	Ground Water	-	-	-	-	-	-	-	-					
	Ground Loop	42,600	19.1	33,100	26.2	31,500	3.7	25,800	4.0					
NEW ZT042 COAX	Water Loop	41,200	15.5	30,500	16.9	49,500	4.7	35,800	5.2	21.2"	21.7"	56"	Add 2.4" to width w/filter rack	280
	Ground Water	46,000	23.4	34,800	30.5	40,100	4.4	28,900	4.6					
	Ground Loop	43,000	18.0	33,500	25.3	32,900	3.6	26,400	4.1					
ZT048 BPHE	Water Loop	47,600	15.8	36,200	17.8	58,300	4.9	42,000	5.5	21.2"	21.7"	56"	Add 2.4" to width w/filter rack	293
	Ground Water	-	-	-	-	-	-	-	-					
	Ground Loop	49,800	18.3	39,700	26.6	37,900	3.9	29,600	4.3					
ZT048 COAX	Water Loop	46,500	15.1	34,600	16.6	55,300	4.8	40,400	5.5	21.2"	21.7"	56"	Add 2.4" to width w/filter rack	293
	Ground Water	52,200	22.1	39,600	29.4	45,900	4.4	32,800	4.6					
	Ground Loop	48,700	17.3	38,000	24.4	36,900	3.6	29,300	4.1					
ZT060 BPHE	Water Loop	59,400	16.3	42,900	18.3	74,600	5.1	51,400	5.8	21.2"	24"	61"	Add 2.4" to width w/filter rack	303
	Ground Water	-	-	-	-	-	-	-	-					
	Ground Loop	61,200	18.7	47,300	26.9	48,100	3.9	34,200	4.1					
ZT060 COAX	Water Loop	55,100	14.6	42,000	16.5	70,700	4.7	50,900	5.4	21.2"	24"	61"	Add 2.4" to width w/filter rack	303
	Ground Water	62,000	21.2	47,300	27.9	58,500	4.2	41,300	4.5					
	Ground Loop	59,000	16.9	45,800	23.7	46,800	3.6	36,400	4.0					
ZT072 BPHE	Water Loop	68,100	15.7	53,400	17.8	88,400	4.8	66,600	5.6	21.2"	24"	61"	Add 2.4" to width w/filter rack	312
	Ground Water	-	-	-	-	-	-	-	-					
	Ground Loop	70,400	18.0	57,100	25.2	57,900	3.8	47,600	4.2					
ZT072 COAX	Water Loop	66,600	13.7	50,700	15.2	83,200	4.5	62,700	5.1	21.2"	24"	61"	Add 2.4" to width w/filter rack	312
	Ground Water	73,500	19.2	58,100	24.8	67,500	4.0	49,200	4.2					
	Ground Loop	69,500	15.6	56,000	21.3	55,500	3.4	44,400	3.8					

Notes:

1. Rated in accordance with AHRI/ISO standard 13256-1, which includes pump penalties.
2. Heating capacities based on 68.0°F DB, 59.0°F WB entering air temperature. Cooling capacities based on 80.6°F DB, 66.2°F WB entering air temperature.
3. GLHP (Ground Loop Heat Pump) entering water temps are 32°F heating/77°F cooling for full load and 41°F heating/68°F cooling for part load. GLHP ratings based upon 15% methanol by weight.
4. GWHP (Ground Water Heat Pump) entering water temps are 50°F heating/59°F cooling for full and part load.
5. WLHP (Water Loop Heat Pump) entering water temps are 68°F heating/86°F cooling for full and part load.
6. Not all units are rated for all standards.
7. Models above 135,000 Btu/hr are outside of the scope of AHRI 13256-1 and the ENERGY STAR program.
9. For water fitting type/diameter, electrical data, extended data, and other product details, consult unit submittal data (commercial) or catalog (residential).

*VS060 with PSC blower, VS072 with PSC or ECM are not ENERGY STAR qualified models.



Model	Type	Cooling				Heating				Dimensional Data			Unit Weight (lbs)	
		Full Load	EER	Part Load	EER	Full Load	COP	Part Load	COP	Height	Width	Depth		
HP — High Performance — High Temperature Water-to-Water — Water-to-Water												Src. In	Load In	248
												Src. Out	Load Out	
HP024	Ground Loop	—	—	—	—	23,000	3.1	—	—	21"	27.75"	24.5	1 1/4"	3/4"
WV — Variable-Speed — Water-to-Water												Src. In	Load In	320
												Src. Out	Load Out	
WV060	Ground Loop	43,000	18.4	21,600	25.4	54,600	3.0	27,000	3.9	37.2"	25.1"	25.1"	1"	1"
WT — Two-Stage — Water-to-Water												Src. In	Src. Out	334
												Load In	Load Out	
WT036	Ground Water	43,500	20.5	33,300	24.1	46,100	3.8	32,500	3.6	23"	26"	32"	1 1/4"	1 1/4"
	Ground Loop	41,200	15.7	32,100	20.2	36,700	3.0	28,800	3.1					
WT048	Ground Water	54,300	19.8	40,800	23.0	55,100	3.6	40,500	3.4	23"	23"	39"	1 1/4"	1 1/4"
	Ground Loop	49,400	15.1	38,800	19.2	44,100	3.0	35,700	3.1					
WT060	Ground Water	62,300	20.7	47,900	23.1	66,900	3.9	50,100	3.7	23"	23"	39"	1 1/4"	1 1/4"
	Ground Loop	57,900	15.8	45,800	19.2	52,400	3.1	44,300	3.2					
WS — Single-Stage — Water-to-Water												Src. In	Src. Out	210
												Load In	Load Out	
WS036	Ground Loop	36,100	17.3	—	—	31,600	3.1	—	—	29.2"	23.4"	25.8"	1 1/4"	1 1/4"
WS048	Ground Loop	49,400	16.6	—	—	45,700	3.2	—	—	29.2"	23.4"	25.8"	1 1/4"	1 1/4"
WS060*	Ground Loop	58,100	16.6	—	—	53,700	3.2	—	—	29.2"	23.4"	25.8"	1 1/4"	1 1/4"
WS072	Ground Loop	72,500	16.7	—	—	62,800	3.1	—	—	29.2"	23.4"	25.8"	1 1/4"	1 1/4"
WS084	Ground Loop	84,300	16.1	—	—	70,100	3.1	—	—	29.2"	23.4"	25.8"	1 1/4"	1 1/4"

Notes:

1. Rated in accordance with ISO Standard 13256-2, which includes pump penalties.
2. GLHP (Ground Loop Heat Pump) entering source temps are 32°F heating/77°F cooling for full load and 41°F heating/68°F cooling for part load. Entering load temps are 104°F heating/53.6F cooling. GLHP ratings based upon 15% methanol by weight.
3. GWHP (Ground Water Heat Pump) entering source temps are 50°F heating/59°F cooling for full and part load. Entering load temps are 104°F heating/53.6F cooling.
4. WLHP (Water Loop Heat Pump) entering water temps are 68°F heating/86°F cooling for full and part load. Entering load temps are 104°F heating/53.6F cooling.
5. Not all units are rated for all standards.
6. Models above 135,000 Btu/hr are outside of the scope of AHRI 13256-2 and the ENERGY STAR program.
7. For water fitting type/diameter, electrical data, extended data, and other product details, consult unit submittal data (commercial) or catalog (residential).

Model	Size (tons)	Dimensional Data All Dimensions In Inches			Return Air Opening Width	Return Air Opening Depth	Unit Weight (lbs)
		Height	Width	Depth			
DX Series, R410A, Multi-Position Air Handlers							155
EAD018	1.5	47.0	18.0	21.5	20.0	16.5	
EAD024	2	47.0	18.0	21.5	20.0	16.5	155
EAD036	3	53.6	21.5	21.5	20.0	20.0	190
EAD048	4	53.6	21.5	21.5	20.0	20.0	190
EAD060	5	53.6	25.0	21.5	20.0	20.0	210
EAD072	6	53.6	25.0	21.5	20.0	20.0	210
MP Series Multi-Position Hydron Air Handlers							135
MPH024	2	43.0	17.6	21.0	16.0	20.3	
MPH036	3	48.3	21.1	21.0	20.0	20.8	165
MPH048	4	58.8	25.0	22.0	23.5	20.8	210
MPH060	5	58.8	25.0	22.0	23.5	20.8	215

Model	Size (tons)	Dimensional Data All Dimensions In Inches			Water Connection Size (Sweat "L" Copper)		Unit Weight (lbs)
		Height	Width	Depth	Liquid	Suction	
DX Series, R410A, Cased "A" Coils							80
EED018	1.5	25.4	18.0	21.5	3/8	5/8	
EED024	2	25.4	18.0	21.5	3/8	5/8	80
EED036	3	30.4	21.5	21.5	3/8	3/8	95
EED048	4	30.4	21.5	21.5	3/8	3/4	95
EED060	5	30.4	25.0	21.5	3/8	7/8	100
EED072	6	30.4	25.0	21.5	3/8	7/8	100
AC Series Hydronic Uncased "A" Coils							36
ACH024	2	18.5	16.6	19.0	3/4	3/4	
ACH036	3	21.0	19.6	19.0	3/4	3/4	43
ACH060	4 - 5	28.0	23.9	20.5	3/4	3/4	64
MC Series Hydronic Cased "A" Coils							56
MCH024	2	20.0	17.5	21.0	3/4	3/4	
MCH036	3	24.0	21.0	21.0	3/4	3/4	68
MCH060	4 - 5	34.0	24.5	21.5	3/4	3/4	101

The Best Geothermal Warranty!

The highest quality product should have a warranty that reflects confidence in its design and construction. Hydron Module strives to embody this principle in the way we stand behind our products. All Hydron Module geothermal systems are backed by Enertech Global, the manufacturer of the Hydron Module brand. The standard residential warranty includes parts and labor coverage, plus coverage on select accessories. That's peace of mind!

At Enertech, quality assurance is one of the guiding principles in the way we do business. We realize that successful business relationships are earned by providing superior products backed by the highest quality technical and customer support.

Our Standard Warranty includes:

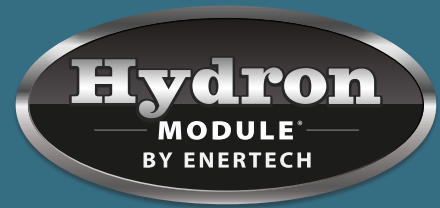

■ **10-Year Warranty** on All Unit Components:

- Cabinet
- Compressor
- Water-to-refrigerant heat exchanger
- Air-to-refrigerant heat exchanger (not applicable on hydronic units)
- All internal refrigerant circuit parts
- All internal water circuit parts
- All internal controls/electrical parts

■ **10-Year Warranty** on Select Accessory Items:

Must be purchased through Hydron Module and includes:

- Flow centers
- Internal plenum and closed coupled auxiliary heaters
- Air handlers and a-coils (for split system and hydronic applications)
- EWC Zoning

■ **5-Year Warranty** on Thermostats

Must be purchased through Hydron Module

■ **5-Year Labor Allowance*** on the Following Items:

- All standard unit components
- Flow centers
- Internal plenum and closed coupled auxiliary heaters
- Air handlers and a-coils (for split system and geothermal hydronic applications)

Get a FREE warranty upgrade that includes an additional 5-year labor allowance (covering years 6 – 10) at no cost by registering your unit within 60 days of installation. In order for registration to be valid, all information on the warranty registration form must be the original owner's accurate information.



Option 18 Warranty: Hydron Module offers the best standard geothermal warranty – pure and simple. To make Hydron Module's warranty offerings even better than its best, we offer the Option 18 Warranty, which covers a one-time replacement for both the compressor and all-aluminum microchannel air coil (if applicable) to the original homeowners up to 18 years. This coverage ends 18 years from the installation date.

Optional warranty reductions available with the 5/5/5 or 10-year parts only warranty. The Option 18 Warranty is not available with reduced warranty coverage options.

*5-Year Labor Allowance is transferable from original homeowners to new homeowners.

Warranty options may vary depending on product. Consult the price book for complete warranty details.



Enertech University curriculum is developed from our history and reputation as a leader in the geothermal heating and cooling industry. Stemming from the grass roots of geothermal technology, backed by manufacturing expertise, and supported by field experience, courses are designed to provide the knowledge and confidence of designing, selling, installing and servicing Enertech made geothermal systems.

Enertech University offers training for the complete geothermal industry. IGSHPA certification and NATE continued education hours are incorporated into our curriculum along with specific design and sales courses for Enertech manufactured equipment.

As further commitment to providing contractors with more tools to grow their business, Enertech University also offers solar PV training, supported by the solar brands we distribute. These trainings include design, sales, and installation of systems.

All training sessions are geared towards technicians, designers, or sales personnel specific to the HVAC and the solar industry. Training will be coordinated through Enertech's corporate office and our distributing partners.

AVAILABLE COURSES INCLUDE:

- Product Installation**
- Fusion Training**
- Basic Geothermal Troubleshooting**
- Advanced Geothermal Troubleshooting**
- Ground Loop & Flow Center Application & Installation**
- Geothermal Hydronic Systems**
- Variable Speed Hydronic Systems**
- Design, Sizing & Software**
- Sales & Marketing**
- Product Introduction/Update**
- IGSHPA/NATE Certified Installer Workshop**
- Solar PV Design, Sales, and Installation**
- Air-to-Water Video Training Modules**

Training Provider



Our Guarantee



We guarantee 100% student satisfaction for every course led by an Enertech trainer.

Online Resources



Enertech University has a growing library of videos and workbooks that can be found online. They're great for geothermal installers who are eager to stay ahead of the curve!

GeoAnalyst[®]

Geothermal Design & Application Software

No other software has as many features.

Even more important, the loop sizing portion uses “pure” IGSHPA algorithms, not manufacturer-adjusted loop sizing formulas. The ease of use and configuration ability provides users with an accurate system analysis at a low annual maintenance fee, which includes free updates.

GeoAnalyst is continually updated with new features. 98% furnaces were recently added, as were 21 SEER air conditioners. Changes in equipment, enhanced features, and other usable upgrades are instantly available in the new online version. There is no longer a need to update the software.

Features

- Ability to compare up to 5 other conventional systems
- Allows the user to save multiple utility files
- I.P. or S.I. utility cost choices (e.g. \$/gallon or \$/liter)
- 14 pre-configured ground loop choices, plus user-defined horizontal loop and open loop (well water)
- “Auto Size” option for sizing loops based upon minimum/maximum entering water temperature
- Economic analysis with simple payback, cashflow analysis, and financing options. Has the ability to include rebates/credits and print graphs
- Choice of HDPE, PEX or user-defined pipe
- Choice of ASHRAE, EPRI or user-defined soil types
- Includes calculations for water-to-water heat pumps and combination units (water-to-water/water-to-air) for applications like radiant floor heating
- Bin data report and balance point calculation
- Includes the latest conventional equipment for comparisons (up to 21 SEER air conditioners/heat pumps and 98% efficiency furnaces)
- Comprehensive system reports for geothermal and conventional selections
- Pressure drop calculation module for sizing flow center pumps (central pumps or pump(s) for each unit)
- Calculates loop flushing requirements, antifreeze requirements, and Reynolds number
- Sales proposal module for creating a consumer-friendly sales proposal to explain the benefits of geothermal vs. the other compared systems
- All new bill of material generator simplifies the quoting and ordering process
- Allows reports to be customized with your company logo and contact information
- Dual-fuel system comparisons for geothermal and air-to-air heat pumps
- “Save as Default” option to use saved local conditions for a new project

Ground Loop Sizing and Operating Cost Analysis

Sample Report

GeoAnalyst ground loop sizing and operating cost analysis is very intuitive with drop-down menus, and pop-up windows. All pre-configured loops have a picture of the cut-away section to help the designer understand the correct inputs. The "Auto Size" option sizes loops based upon the minimum and maximum entering water temperature selected. The designer may also key in the loop length, and allow the software to calculate the minimum and maximum loop temperatures.



GeoAnalyst® Geothermal System Report

1/5/2021

System 1 - Geo System
New Project
Example
Weather Data Location: Abbotsford BC

Heating		Cooling	
Annual Heating Load:	50.5 MMBtu	Annual Cooling Load	4.1 MMBtu
Electricity (Tetco):	3949 kWh	Electricity (Tetco):	195 kWh
Electricity (Auxiliary):	2 kWh	Average Efficiency:	21.1 Btu/Watt
% by Tetco:	100.0 %	Annual Cost:	\$20
Average Efficiency:	3.75 COP	Estimated Annual Operating Costs	
Annual Cost:	\$395	Heating:	\$395
Hot Water		Cooling:	\$20
Annual DHW Load:	5.2 MMBtu	Hot Water:	\$64
Electricity:	642 kWh	Total ^{1,2,3} :	\$479
% by Geothermal:	65.6 %		
Average Efficiency:	2.38 COP		
Annual Cost:	\$64		
Design Heating Load: 55714 Btu/hr		Design Cooling Load: 21666 Btu/hr	
Indoor Design Temperature: 70 °F		Indoor Design Temperature: 75 °F	
Outdoor Design Temperature: -12 °F		Outdoor Design Temperature: 95 °F	
Heating Electric Rate: 0.10 \$/kwh		Cooling Electric Rate: 0.10 \$/kwh	
Hot Water Electric Rate (Htg): 0.10 \$/kwh		Hot Water Electric Rate (Clg): 0.10 \$/kwh	
Winter Peak Electrical Demand: 2.74 kW		Summer Peak Electric Demand: 1.54 kW	
Model XT036 XT Series with hot water generator		Emergency Heat: 8.56 kW	
Water Heater: Electric		Balance Point: 13 °F	
Auxiliary Heat: 0.30 kW			
Loop Type / Soil: Two Vertical U-Tubes, Polyethylene SDR-11 3/4" / Heavy Soil Saturated		Deep Earth Temp: 52 °F	
Bore Depth: 150 ft		Annual Temperature Swing: 17 °F	
Total Bore / Pipe: 265 / 1060 ft		Phase Shift: 39 Days	
		Soil Conductivity: 1.4 Btu/hr-ft-F	
		Soil Diffusivity: 0.04 ft²/hr	
		Pipe Conductivity: 0.226 btu/hr-ft-F	

Analysis

ENERTECH ENERGY + TECHNOLOGY

System 1 - Geo System

Loop Information

Loop Type: Pond Mat Loop

Pump: UP26-99

Entering Water Temperature

Desired

Maximum (Summer): 100

Minimum (Winter): 25

Geo Unit

Series: XT Series

Unit: XT036

Backup Heating

Electric

ECM Blower is assume for all Geo Units

Hot Water

Electric

DesuperHeater

Calculate Return to Project Page Help

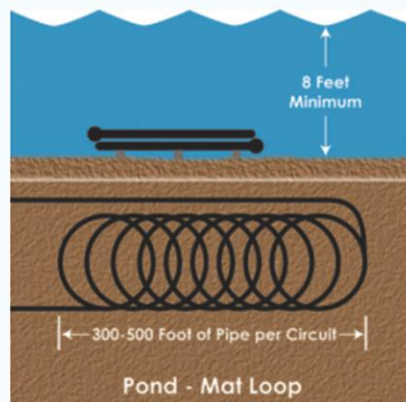

Visit www.geoanalyst.net to try the demo or to register - or call 618-664-5860 to learn more!

Access Online

The web-based GeoAnalyst combines all the great features you've come to expect with the flexibility of accessing the software from a computer or mobile device anywhere, whether in your office, home or on the jobsite! Plus geoanalyst.net offers unlimited users for one low annual license fee. Visit www.geoanalyst.net to try out the demo software for free or register for a full license.

Hydron Module Marketing

Good communication turns ordinary relationships into extraordinary ones. Our goal is to enhance your business by providing monthly newsletters for reminders and updates, video libraries on YouTube, and various email and social media communications. Our support site has everything you need to promote Enertech products through digital channels like social media, your website, and search, in your office, on your vehicles, and more.

Sales Support

We offer items that supplement and enhance your sales process, and we aim to deliver you leads so you can install more products with less time invested on the consumer education side. Here's how we accomplish this:

LITERATURE

- Product Brochures
- Guides and Whitepapers
- Presentation Templates
- Tax Credit Certificates

LEAD GENERATION

- Digital advertising campaigns at the local, state, and national level
- Home Shows, Agricultural Fairs, and Trade Shows
- Traditional advertising efforts at the local, state, and national level
- Dealer website program

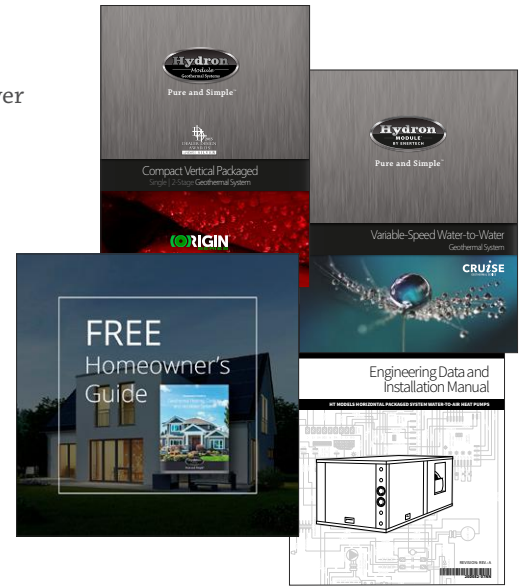

Advertising Resources

The advertising resources we offer will set you apart from your competitors. With our branding and messaging along with yours, we've got a full toolkit to help you advertise in your local area. Here's an example of the materials we offer – free of charge:

- Print Ads
- Direct Mail
- Radio Ads
- Outdoor
- Digital Ads
- Installation Spotlights
- Apparel
- Event Graphics

Graphic Resources

Got a project that's a bit more unique to your brand? You can pick and choose which of our graphic resources you want to use to complete the project. The following can be used on your website, company vehicles, etc.:

- Product Photography
- Logos
- Icons
- Illustrations

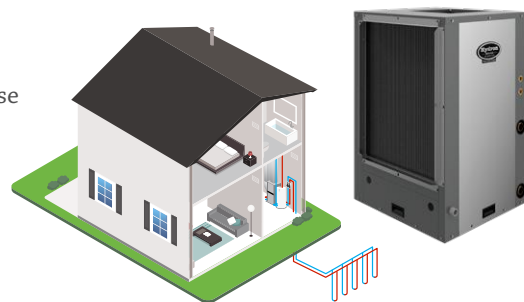

Branding Support

Talk to your Territory Manager about our Branding Support options. We'll help you cover advertising expenses whenever you feature our brand in a way that follows the guidelines.

Installation Spotlights



GEOTHERMAL INSTALLATION
Spotlight

Elegant Missouri River Ranch Washington, MO

This healthy home is nestled in Washington, Missouri, the corn-cob pipe capital of the world. When the homeowners set out to build a new home in this small town along the Missouri River, they prioritized both a low energy profile and superior comfort for their family. The house was founded and sealed to create a very tight envelope, and Jim's Heating and Cooling took the healthy home features to the next level by applying elements of the 2012 Energy Code to the heating and cooling system. The home also incorporates many beneficial accessories to fulfill the homeowners' energy cost and comfort requirements, including steam humidifiers and energy recovery ventilators.

Project Details

Building Size: 4,500 sq. ft.	
Loop Type: Vertical	
Geothermal Equipment: 5-ton Hydron Module Combination unit, 3-ton Hydron Module Multi-Positional Vertical Packaged unit	
Installation Date: March 2016	

Installation Details: The lower floor has in-floor radiant heating, involving five circuits. A Honeywell four-zone system was used with the forced air geothermal system to provide a temperature control system that matched the homeowners' lifestyle. Two Aprilaire steam humidifiers were also added to provide lower energy costs, a healthier home environment, and increased comfort. Energy recovery ventilators (ERVs) were added to each system in order to continually provide fresh air, reducing VOCs. This was all connected by four Aprilaire multi-stage touchscreen thermostats that integrated the steam humidifiers and ERVs into a one-device control center. A vertical loop was used even though there was a large lake available. Both options were assessed with a cost/benefit analysis and it was determined the vertical loop was the more beneficial option.

Geothermal Contractor: Jim's Heating & Cooling • Washington, MO • (636) 239-3581
www.jimsheatandcool.com

Project Details

Building Size:	4,500 sq. ft.	CONSTRUCTION TYPE New Construction SYSTEM TYPE Forced Air System SYSTEM TYPE Radiant System LOOP TYPE Vertical Loop
Loop Type:	Vertical	
Geothermal Equipment:	5-ton Hydron Module Combination unit, 3-ton Hydron Module Multi-Positional Vertical Packaged unit	
Installation Date:	March 2016	
Installation Details:	<p>The lower floor has in-floor radiant heating, involving five circuits. A Honeywell four-zone system was used with the forced air geothermal system to provide a temperature control system that matched the homeowners' lifestyle. Two Aprilaire steam humidifiers were also added to provide lower energy costs, a healthier home environment, and increased comfort.</p> <p>Energy recovery ventilators (ERVs) were added to each system in order to continually provide fresh air, reducing VOCs. This was all connected by four Aprilaire multi-stage touchscreen thermostats that integrated the steam humidifiers and ERVs into a one-device control center.</p> <p>A vertical loop was used even though there was a large lake available. Both options were assessed with a cost/benefit analysis and it was determined the vertical loop was the more beneficial option.</p>	
Geothermal Contractor:	Jim's Heating & Cooling • Washington, MO • (636) 239-3581 www.jimsheatandcool.com	

Project Spotlight ID: PSH-16-0018 ©2016 Enertech Global, LLC

We feature our dealers' installations on our website as Installation Spotlights. This provides free advertising for dealers, and it's collateral to use in the sales process.

GEOHERMAL Ground Loop Field

The heat exchanger, also known as the loop system, captures the stored solar energy in the ground and delivers it back to the geothermal system in the house.

The loop system is the heart of geothermal technology. There are four different types of loops.

Installing a geothermal loop system is like getting up to a 70% discount on energy for the life of the home.

Vertical loops are used mainly when land area is limited in retrofit applications of existing homes. A drilling rig is used to bore holes at of depth of 150 to 300 feet per ton. A U-shaped coil of high density pipe is inserted into the bore hole. The holes are then backfilled with a sealing solution.

Horizontal loops are commonly used when adequate land area is available. Loop installers use excavation equipment such as trenchers, backhoes and track hoes to dig trenches approximately 6 to 8 feet deep. Trench lengths range from 100 to 300 feet per ton, depending on the loop design and application. Directional bore machines can also be used.

Pond loops are an option if a large body of water is available within approximately 200 feet of the home. A ½ acre, 10 to 12 foot deep body of water is usually adequate to support the average home. The system uses coils of pipe typically 300 to 500 feet in length. The coils are placed in and anchored at the bottom of the body of water.

Open loop systems can be installed if an abundant supply of high quality well water is available. A typical home will require a well producing 4 to 8 gallons of water per minute. A proper discharge area such as a river, drainage ditch, stream, pond, or lake must be present. Check for local restrictions before selecting a specific discharge method.

Vertical Loop

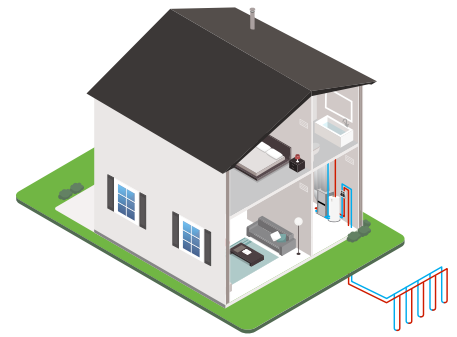

Horizontal Loop

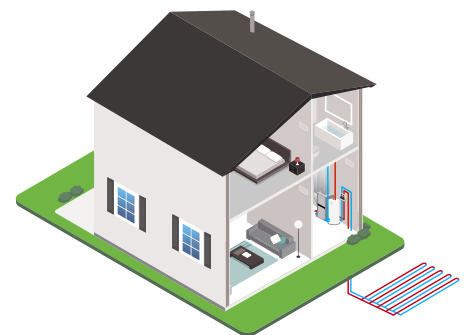

Pond Loop





Open Loop



Enertech's Advantage Air-to-Water Heat Pump

A turnkey solution, bringing modern air-to-water heating, cooling, and hot water capabilities to life.

The first packaged solution to provide:

-  Up to 100% of domestic hot water needs
-  Radiant in-floor heating
-  Forced-air heating and cooling functionality



For almost three decades, water-source and geothermal have been our sole focus. In 2017, we expanded to include the distribution of solar PV systems and in 2020, we started offering batteries and charging stations. Our goal? To live up to our tagline: Where Energy Meets Technology. We're here to provide an easy to achieve, whole home and building energy-independent solution, and our latest, Enertech-manufactured product, the Advantage air-to-water heat pump, is another major step in that direction.

The Advantage is a Monobloc design. The pre-assembled outdoor unit contains the entire refrigerant circuit, eliminating the need for refrigerant lines between the outdoor unit and indoor module. Only water lines run from the outdoor to indoor unit for increased safety and a significantly less complicated installation when compared to traditional air-source heat pumps. The outdoor unit is tested and run-tested at the factory just like our package water-source and geothermal heat pumps.

Efficiency Comparison (COP)

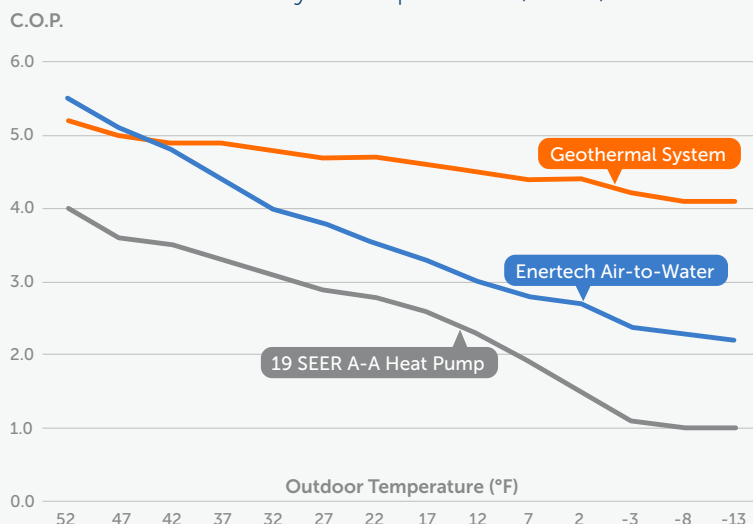

To find out more, visit enertechusa.com/advantage-air-to-water-heat-pump.

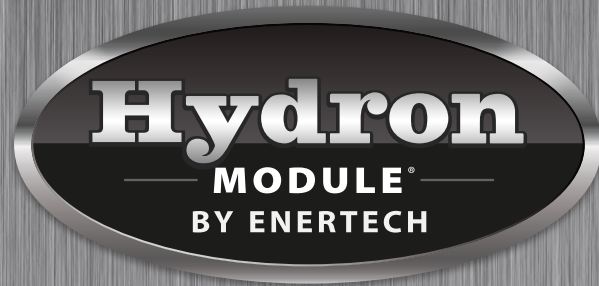

Greenville, IL - Mitchell, SD

info@enertechusa.com

www.hydronmodule.com

Industrial, institutional and commercial buildings often have unique heating and cooling needs. Hydron Module has a complete line of commercial models to fit most any project. Visit hydronmodule.com/commercial-products to learn more!

COMMERCIAL SERIES



Proudly built in Mitchell, SD by



Enertech Global is continually working to improve its products. As a result, the design, specifications, and general information of each product may change without notice and may not be as described herein. For the most up-to-date information, please visit our website, or contact our Customer Relations department at customerrelations@enertechusa.com. Statements and other information contained herein are not express warranties and do not form the basis of any bargain between the parties, but are merely Enertech Global's opinion or commendation of its products.